



A Brief Introduction to Final Medical Reports

PHIL ROBERTS and FRANK SALVI

Dispute Resolution Specialists
DWD Division of Worker's Compensation

Introduction

- Rationale
- Solutions to common problems
- Questions



FMR – Who?

- Temporary disability exceeds 3 weeks
- Permanent disability rated
- Surgery (except hernias)
- Eye injuries with 3 or more medical visits
- Per Wis. Stat. 102.13(2)(c)



FMR – Why?

Rating = Compensation for disability related to injury

- State requirement
- In setting of Independent Medical Examination (IME)
 - Average ratings
 - Helps with dispute resolution
- Verification of benefits owed by statute (if any)



FMR – When?

- End of healing (EOH)
- Maximum Medical Improvement (MMI)
- Dies before EOH



FMR – What? (Necessary Elements)

- Diagnosis
- Date of injury
- Percentage rated for disability described
- End of healing and discharged
- Restrictions
- Signed and dated by MD, DO, DC, or PsyD



FMR – Necessary Details

- For surgery
 - Send operative report
 - Pay what you know
- For fingers
 - Range of motion*
 - CD/DVD or USB stick of x-rays if amputation greater than $\frac{2}{3}$ of the distal phalanx
 - Hand dominance required
- No AMA Guidelines for scheduled injuries



Department of Workforce Development
 Worker's Compensation Division
 201 E. Washington Ave., Rm. C100
 P.O. Box 7901
 Madison, WI 53707-7901
 Telephone: (608) 266-1340
 Fax: (608) 267-0394
 http://dwd.wisconsin.gov/wc
 e-mail: DWDDWC@dwd.wisconsin.gov

MEDICAL REPORT ON INDUSTRIAL INJURY

*Provision of your Social Security Number (SSN) is voluntary. Failure to provide it may result in an information processing delay. Personal information you provide may be used for secondary purposes (Privacy Law, s. 15.04 (1)(m), Wisconsin Statutes).

PATIENT	WC Claim Number	Employee Name		
	Employee Social Security Number*	Employee Address		
	Injury Date	Employer Name	Insurance Company	
HISTORY	History as described by patient			
DIAGNOSIS (Please be as detailed as possible)				
PERMANENT DISABILITY (Describe permanent elements of disability, such as limitation of motion, pain, weakness, etc., and describe effect on working ability.)	What amputation present?	Comparative x-rays taken? <input type="checkbox"/> Yes <input type="checkbox"/> No		Stump: <input type="checkbox"/> hardy or <input type="checkbox"/> tender
	Has permanent disability resulted? <input type="checkbox"/> Yes <input type="checkbox"/> No	Date of Last Exam	Has healing period ended? <input type="checkbox"/> Yes <input type="checkbox"/> No	Patient discharged? <input type="checkbox"/> Yes <input type="checkbox"/> No
	Description of permanent disability (Record finger motion losses on reverse.)			
	Was surgery performed as a result of accident? <input type="checkbox"/> Yes <input type="checkbox"/> No If Yes, state type of surgery:			
If healing has not ended, what is minimum permanent disability expected?				
PRIOR DISABILITY	What previous disability?			
PROGNOSIS	Prognosis:			
	Date injured was or will be able to return to a limited type of work: State any limitations:			
	Date injured was or will be able to return to full-time work subject only to permanent limitations:			
	What further treatment should be given?			
Additional comments, if any:				
Date	City	Physician or Chiropractor Signature (in own writing)		
Phone Number () -		Typed or Printed Name		

WKC-16 (R. 06/2017)

Employee Name	Employee Social Security Number
---------------	---------------------------------

Instructions for finger injuries

Please use statutory terms in referring to fingers, such as thumbs, index, middle, ring, and little fingers, and distal, middle, and proximal joints. Where there is limitation of motion, list separately the normal range of motion in degrees, the "degrees" loss of flexion, and the "degrees" loss of extension for each joint of each finger. The Worker's Compensation Division will evaluate the loss of use due to loss of motion of the fingers.

Where there are other elements of disability of the fingers, such as deformity, weakness, pain, or lack of endurance, give your opinion on the percentage loss of use as compared to amputation for such elements of disability and specify the joint at which such loss is estimated.

Digit	Joint	Angle Ext./Flex	Normal Range of Motion	Degrees Loss Extension	Degrees Loss Flexion	Estimate % loss of use for additional factors at joint involved and reason for additional allowance
Thumb	Dist					
	Prox					
Index	Dist					
	Mid					
Mid	Dist					
	Mid					
Ring	Dist					
	Mid					
Little	Dist					
	Prox					

CIRCLE HAND INVOLVED: Right Left

DOMINANT HAND: Right Left

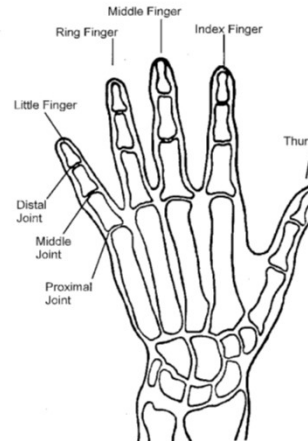

See DWD 80.32 & 80.33 for guides to evaluation for amputations, restrictions of motion, ankylosis, sensory loss, and surgical results for disability to the hip, knee, ankle, toes, shoulder, elbow, wrist, fingers and back.

If fingertip amputation is present, submit comparative x-rays or a statement indicating whether the bone loss was less than one-third, between one-third and two-thirds, or more than two-thirds of the distal phalanx.

If amputation is below the distal joint, submit comparative x-rays.

WKC-16



PHYSICIAN'S REPORT ON EYE INJURIES

Department of Workforce Development
 Worker's Compensation Division
 221 E. Washington Ave., Rm. C100
 P.O. Box 7901
 Madison, WI 53707-7901
 Telephone: (608) 266-1340
 Fax: (608) 267-0394
 http://dwd.wisconsin.gov/wc
 e-mail: DWDDWC@dwd.wisconsin.gov

Refer to Ind. 80.26, Loss of vision; determination

*Provision of your Social Security Number (SSN) is voluntary. Failure to provide it may result in an information processing delay. Personal information you provide may be used for secondary purposes [Privacy Law, s. 15.04 (1)(m), Wisconsin Statutes].

PATIENT	WC Claim Number	Employee Name	
	Social Security Number*	Employee Address	
HISTORY	Injury Date	Employer Name	Insurance Company Name
	Date of First Treatment	Date of Last Treatment or Exam	Which eye is injured? <input type="checkbox"/> Right <input type="checkbox"/> Left <input type="checkbox"/> Both
	If only one eye is injured, is the other eye affected? <input type="checkbox"/> Yes <input type="checkbox"/> No If yes, explain		
NATURE OF INJURY AND DIAGNOSIS	Please be as detailed as possible		
	Is physical condition of the eyes stationary? <input type="checkbox"/> Yes <input type="checkbox"/> No If no, explain:	1) Did cataract form as a result of injury? <input type="checkbox"/> Yes <input type="checkbox"/> No 2) If cataract formed, was lens removed? <input type="checkbox"/> Yes <input type="checkbox"/> No 3) Has there been a surgical implant of lens? <input type="checkbox"/> Yes <input type="checkbox"/> No	Danger of further impairment? <input type="checkbox"/> Yes <input type="checkbox"/> No If yes, explain:
CENTRAL VISUAL READINGS	Distance → Use Snellen test letters or characters up to 20/800.		
	Near → Use AMA Reading Card up to 14/560.		
IMPORTANT: PLEASE FILL OUT EACH LINE COMPLETELY FOR EACH EYE	After injury		Pre-existing before injury, including presbyopia and other conditions clearly not the result of the injury.
	Without Correction		Without Correction
	With Correction		With Correction
	Distance	Near	Distance
Right			Right
Left			Left
PRIOR DISABILITY	Did the employee wear glasses for pre-existing subnormal vision?	<input type="checkbox"/> Yes <input type="checkbox"/> No	
	Is there a record or positive indication of pre-existing subnormal vision?	<input type="checkbox"/> Yes <input type="checkbox"/> No If yes, Explain:	
BINOCULAR VISION	Is there absence of useful binocular vision?	<input type="checkbox"/> Yes <input type="checkbox"/> No	
	Explain cause: If a result of the injury, what is the percentage of additional permanent disability?		
	Is there any diplopia present?	<input type="checkbox"/> Yes <input type="checkbox"/> No	
	If yes, this should be plotted in the chart at the right by placing an X in each square in which diplopia is found. The test is to be made with any industrially useful correction applied.		
Was such correction used?	<input type="checkbox"/> Yes <input type="checkbox"/> No		

WKC-16-A (R. 06/2017)

FIELD VISION

Field vision taken without correction if possible using a white test object which subtends one degree and a standard parameter with a radius of 12.8 inches (325 mm). The test object shall measure 0.223 inches (5.8 mm). Is there any loss of the field of vision? Yes No Is it the result of the injury? Yes No If so, indicate on the charts and table below. Sketch impaired area. Sketch areas of any scotomata.

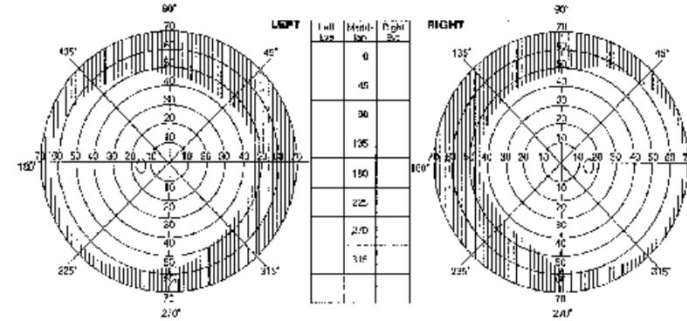

When did the last trace of inflammation disappear from the eye?

Date able to return to work

OTHER FUNCTIONS

Certain ocular disabilities are not covered in the foregoing sections, such as disturbance of accommodation, of color vision, of adaptation to light and dark, nystagmus, strabismus, nyctalopia, diplopia, hemianopia, and muscle disturbances not included under diplopia. Is any such disability present? If so, explain under "Remarks" below, stating whether it results from the injury, what it is, which eye, or whether both eyes are affected, and your percentage estimate of the impairment of the eye or eyes for industrial use.

Remarks:

Doctor Signature: _____ Date signed: _____
(Do not write doctor's own name/initials)

Address:

WKC-16-A



Commonly Encountered Problems

- Opinion of unauthorized clinician
- Disability described but not rated, or rating does not meet statutory requirements
- FMR missing one or more required elements
- Additional required documentation
- Doctor unresponsive to FMR request or unavailable
- Patient does not return to doctor for assessment



Unauthorized Clinician

- Signed by Advanced Practice Registered Nurse (APNR), physician assistant-certified (PA-C), dentist, counselor
- Acceptable if MD, DO, DC, or PsyD co-signs



Disability Described but Not Rated

- Surgery with statutory minimum rating
- Decreased range of motion
- Permanent restrictions
- Other elements of disability: **If present, shall result in a higher estimate!**
 - Pain
 - Weakness
 - Activity limitation
 - Altered sensation
 - Unstable grafts



FMR Missing Required Elements

- Check box form missing one or more required elements
- End of healing box was not checked
- Disability was not assigned to a body part
- Extent of amputation
- Rating of scheduled disability uses AMA Guides to Impairment



Additional Required Documentation

- Operative reports for stat min surgeries
- TTD payment when no lost time beyond 3-day waiting period
- X-rays for significant finger amputations
- IME sent without final medical report
- IME supplemental report sent without original IME report
- IME sent without position letter (unless paying average)



Doctor Unresponsive or Unavailable

- No response to 3 or more timely requests for FMR
- Doctor refuses to complete FMR
 - “I don’t do disability ratings”
 - Injured worker did not return
 - Injured worker still treating
- Doctor moved or no longer practicing
 - Deferred opinion



Common Procurement Problems

- Employee does not attend final evaluation
- Denial letter following IME
- No timely response from providers



Getting Help: Forms GL-15 and GL-10

- GL-15
 - Sent when the insurer provides DWD with three or more written requests to the treating provider to get a final medical after EOH is reached with them. **We require treating provider's name and address to send this form.**
- GL-10
 - Sent to injured worker when the provider doesn't respond to DWD or when claimant is lost to follow-up
- 60-day internal follow-up for both forms



Uncommon Procurement Issues

- Refusal to attend IME
- Out of state treatment
- Treatment for injuries not work-related
- Incarceration
- Missing claimants



Refusal to Attend IME

- Immediately let us know after the first no-show
- If a no-show for the second, contact us and ask an ALJ to compel attendance
- Benefits cannot be suspended until an ALJ approves



Out of State Treatment

- Claimant and MD must be educated on basics of WI worker's compensation
- If you will not authorize care, help the claimant to secure a referral from their WI MD
- MD may not understand claim jurisdiction
- We will not close an out-of-state claim without a remarkable effort to secure FMR
- Out of country: call for immediate help



Treating for Other Injuries

- Injuries not work-related may keep MD from declaring EOH for work injury
- These claims cannot be closed and reopened later
- Keep us informed of treatment progress so we have something on file
- Due dates will always be pushed out if we have proof of ongoing treatment



Incarceration

- Approached the same way as if treating for another injury
- Tell us immediately so we can push out the due date
- Mail the claimant a letter saying the follow-up visit and mileage will be paid
- Staff of correctional facility not accepted for final medical report



Missing Claimants

- When PPD is known, these funds must still be paid; insurers cannot hold
- Inform us immediately and
 - Mail a letter to claimant's last known address asking for contact
 - Mail a letter to any known dependents or employer asking for contact
 - CC all letters to us



Missing Claimants (cont.)

- If whereabouts still unknown, contact Dept. of Revenue to pay the Unclaimed Property Fund
- Submit a WKC-13 to show payment



Additional Tips

- Use the Pending Reports System to update the medical report expected due by date
 - Do not tell us via WKC-13 notes
- Review the medical sent for the necessary elements needed to close a claim - a WKC-16 may not be required
- Timely issue PPD payments to avoid surcharges and/or a delay audit
- If you are not sure about how to handle a particular claim, give us a call!



Wisconsin Department of Workforce Development Worker's Compensation Division

(608) 266-1340

<https://dwd.wisconsin.gov/wc/>

Phil Roberts, DRS

(608) 264-8783

Philip.Roberts@dwd.wisconsin.gov

Frank Salvi, DRS

(608) 267-4327

Frank.Salvi@dwd.wisconsin.gov



DWD.WISCONSIN.GOV